

# Quad Channel Inductive Loop Vehicle Detector (Q.L.D. V1)

Hardware version: v1.0

Firmware version: v0.9

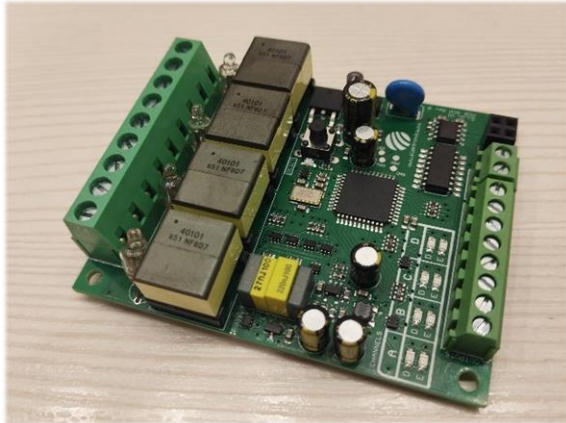

Variant: **4CH** (4 channels, digital configuration)

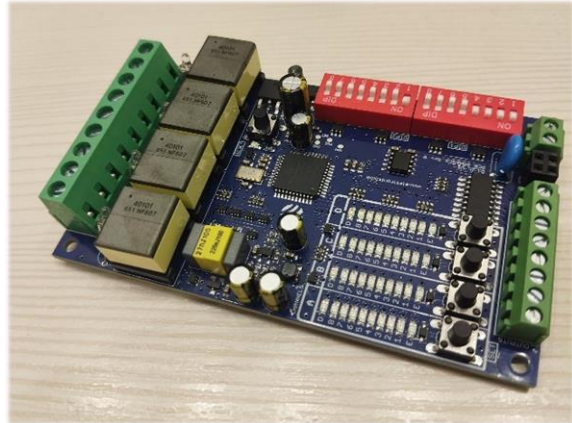

Variant: **4CH+UI.1** (4 channels + user interface „1“)

## Technical details

PARAMETER	DESCRIPTION
<b>OPERATING MODES</b>	Independent channels Directional Logic (2 independent groups) Combination of directional logic and independent channels
<b>CALIBRATION</b>	Automatic
<b>DETECTION TYPE</b>	Presence / Pulse, independent for each channel
<b>OUTPUT PULSE DURATION</b>	250 ms / 500 ms (adjustable)
<b>PRESENCE TIME</b>	Adjustable in 3 steps (SHORT, MEDIUM, LONG)
<b>SIGNAL FILTERING</b>	Adjustable in 2 steps (NORMAL, HIGH)
<b>FREQUENCY SELECTION</b>	4 combinations (LOW, MED-LOW, MED-HIGH, HIGH)
<b>SENSITIVITY</b>	Maximum 0.0025% $\Delta f/f$ , adjustable in 8 steps
<b>RESPONSE TIME</b>	8.5 ms per channel (adjustable in range 3 ms – 12.5 ms)
<b>START-UP</b>	~ 2 seconds per channel Warm-up option available Autotuning option available
<b>POWER SUPPLY</b>	Please refer to <b>Variants</b> section of this document
<b>LOOP INDUCTANCE</b>	20 uH – 1000 uH
<b>FREQUENCY RANGE</b>	22 kHz – 200 kHz
<b>TEMPERATURE RANGE</b>	-35°C – 120°C
<b>SENSOR PROTECTION</b>	Galvanic isolation, gas discharge tube, Zener clamping

# Contents

- Variants ..... 4
  - Variant: 4CH ..... 4
    - Components ..... 5
    - Connectors ..... 5
    - Known issues ..... 6
  - Variant: 4CH+UI.1 ..... 6
    - Components ..... 7
    - Connectors ..... 8
    - Known issues ..... 8
- Features of the detector ..... 9
  - Loop oscillation frequency ..... 9
  - Detection sensitivity ..... 9
  - Slow startup (Warm up) ..... 9
  - Detect LED mapped to output ..... 9
  - Delayed Runtime Re-Calibration ..... 9
  - Autotune on startup ..... 9
  - Additional signal filtering ..... 10
  - Fail Safe ..... 10
  - Inverted output ..... 10
  - Delay output activation ..... 10
  - Blink frequency on startup ..... 10
  - PPC – permanent presence canceller ..... 10
  - Detect Stop ..... 10
  - ASB – Automatic Sensitivity Booster ..... 11
  - Factory Reset ..... 11
  - PC Configurator Software ..... 11
- Configuration of the detector ..... 12
  - General configuration ..... 12
  - Channel specific configuration ..... 13
  - Operating Mode: “Independent channels” ..... 14
  - Operating Mode: “Directional Logic A+B and/or C+D” ..... 15
  - Operating mode: “Combination of directional logic and independent channels” ..... 16

Additional information ..... 17

    Channel Outputs..... 17

    PC Configurator ..... 17

Problem diagnostics ..... 19

Document History ..... 20

## Variants

This loop detector (Q.L.D. V1) exists in different variants with the same functionality and same firmware. Different variants exist in order to satisfy different requirements for installation and use-case scenarios.

### Variant: 4CH

Variant **4CH** is intended for installation into existing solutions, e.g. car parking management systems, where low DC voltage power supply is already available and connecting high-current loads is not required. This version is the minimum of what is required for a fully functional standalone 4 channel loop detector. If required, further minimization is also possible by removing channel outputs, channel indicators (LEDs) and UART isolator IC. In this case information about channel detection must be read from the UART port. It is also possible to reduce the number of channels if necessary (i.e. to have 1, 2 or 3-channel detector instead of 4) with no changes to firmware.

**Note:** In order to ensure stable detector operation, make sure that detector is protected from rapid temperature changes (e.g. cooling by air is not permitted). Detector should be installed in a closed box.

By default, the detector is configured as an independent 4 channel loop detector with outputs configured in **presence output**. Any further configuration of this variant of the detector must be done via specialized PC Configuration software. For further information please refer to section **PC Configurator**.

<i>Parameter</i>	<i>Value</i>
<i>Supply voltage</i>	Recommended: <b>12V DC</b> Absolute range: 9-24V AC/DC Voltage regulator: linear 78M05
<i>Outputs</i>	Open-collector, optically isolated
<i>Communication</i>	Isolated UART TTL (115200, 57600, 19200, 9600 bps)
<i>Current consumption</i>	0.022A (0.26W) @ 12V DC
<i>Indication</i>	Detect and Error LEDs for each channel
<i>Connectors</i>	Screw terminals
<i>Mounting</i>	4 holes
<i>PCB dimensions</i>	72 x 59 mm

## Components

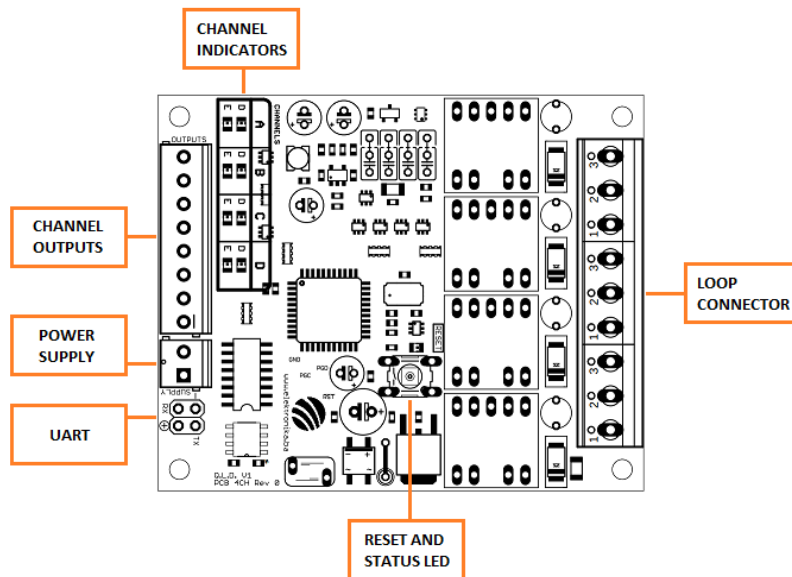

Component	Description
<b>Reset and Status LED</b>	Button to reset the detector
	LED indicator that blinks in ~1/4 Hz rate to report correct detector operation
<b>Channel outputs</b>	Open-collector output for each channel (4 total)
<b>Power supply</b>	Power supply for the detector. Polarity <b>not</b> important.
<b>Channel indicators</b>	<b>DETECT</b> LED (green) for each channel (4 total)
	<b>ERROR</b> LED (red) for each channel (4 total)
<b>UART</b>	4-pin connector for connecting the sensor to embedded devices
<b>Loop connector</b>	9 pin connector for connecting 4 loops and 1 ground terminal

## Connectors

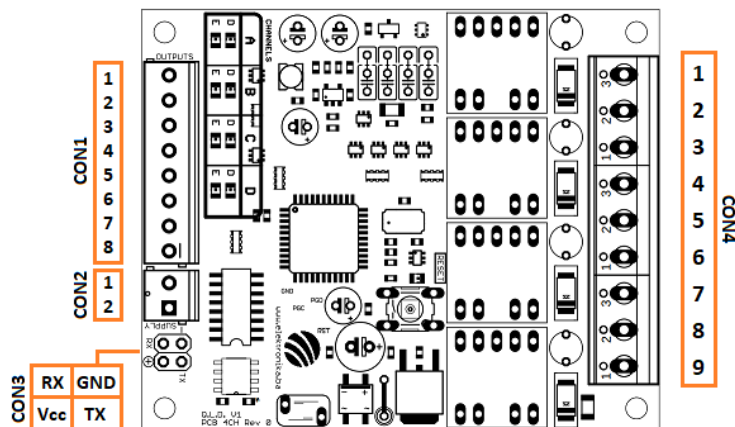

PIN	CONNECTOR: CON1	DESCRIPTION
1	Channel D – Emitter	Emitter terminal
2	Channel D – Collector	Collector terminal
3	Channel C – Emitter	Emitter terminal
4	Channel C – Collector	Collector terminal
5	Channel B – Emitter	Emitter terminal

6	Channel B – Collector	Collector terminal
7	Channel A – Emitter	Emitter terminal
8	Channel A – Collector	Collector terminal

PIN	CONNECTOR: CON2	DESCRIPTION
1	Power supply terminal 1	AC or DC
2	Power supply terminal 2	AC or DC

PIN	CONNECTOR: CON3	DESCRIPTION
RX	Data receive	Input
TX	Data transmit	Output
GND	Ground	0V
Vcc	Supply for UART isolator	3V – 5.5V

PIN	CONNECTOR: CON4
1 & 2	Loop channel D, loop connection
3 & 4	Loop channel C, loop connection
5 & 6	Loop channel B, loop connection
7 & 8	Loop channel A, loop connection
9	Earth terminal

### Known issues

Date	PCB revision	Description	Fix
2024-12-01	Rev 0	Missing pull-up resistor for UART port	Added 1k8 0603 resistor between RX and Vcc lines at the output of UART isolator IC, between pins 1 & 2.
2024-01-09	Rev 0	Digital outputs silk-screening is in reverse. Channels are labelled in reverse.	Ignore silk-screening for digital outputs on the PCB.

### Variant: 4CH+UI.1

Variant **4CH+UI.1** is intended for installation into existing solutions, e.g. car parking management systems, where low DC voltage power supply is already available and connecting high-current loads is not required. This variant also supports configuration via DIP switches which is useful for deploying the detector where different configuration is required on the field, and it also has LED bar-graphs to show current sensitivity and current detection level for each channel.

**Note:** In order to ensure stable detector operation, make sure that detector is protected from rapid temperature changes (e.g. cooling by air is not permitted). Detector should be installed in a closed box.

Additional configuration of this variant can also be done via specialized PC Configuration software. For further information please refer to section **PC Configurator**.

<i>Parameter</i>	<i>Value</i>
Supply voltage	Recommended: <b>12V DC</b> Absolute range: 9-24V AC/DC Voltage regulator: linear 78M05
Outputs	Open-collector, optically isolated
Communication	Isolated UART TTL (115200, 57600, 19200, 9600 bps)
Current consumption	0.024A (0.28W) @ 12V DC
Indication	Sensitivity bar-graphs, Detect and Error LEDs for each channel
Connectors	Screw terminals
Mounting	4 holes
PCB dimensions	98 x 59 mm

## Components

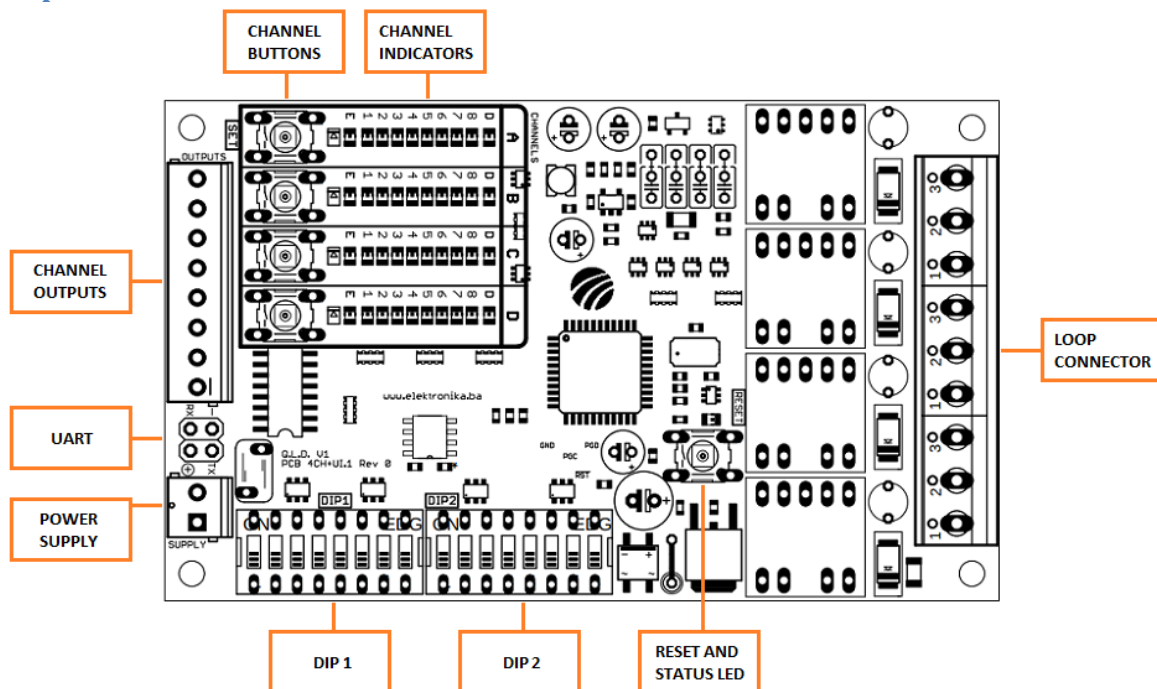

Component	Description
<b>Reset and Status LED</b>	Button to reset the detector
	LED indicator that blinks in $\sim 1/4$ Hz rate to report correct detector operation
<b>Channel outputs</b>	Open-collector output for each channel (4 total)
<b>Power supply</b>	Power supply for the detector. Polarity <b>not</b> important.
<b>Channel indicators</b>	<b>DETECT</b> LED (green) for each channel (4 total)
	Sensitivity bar-graph – 8 levels for each channel (4 total)
	<b>ERROR</b> LED (red) for each channel (4 total)
<b>Channel buttons</b>	Buttons for changing channel sensitivity for each channel
<b>UART</b>	4-pin connector for connecting the sensor to embedded devices
<b>Loop connector</b>	9 pin connector for connecting 4 loops and 1 ground terminal
<b>DIP1 &amp; DIP2</b>	DIP switches for detector configuration (2 total)

## Connectors

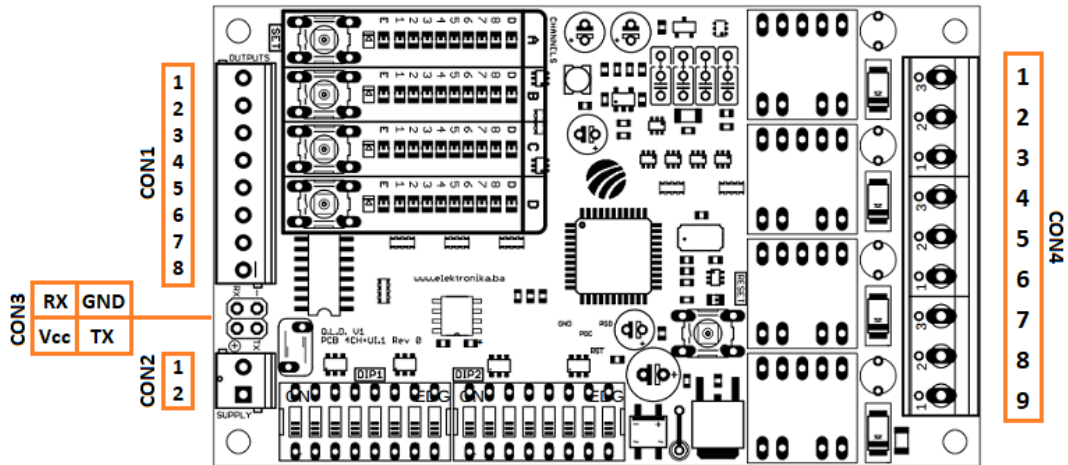

PIN	CONNECTOR: CON1	DESCRIPTION
1	Channel D – Emitter	Emitter terminal
2	Channel D – Collector	Collector terminal
3	Channel C – Emitter	Emitter terminal
4	Channel C – Collector	Collector terminal
5	Channel B – Emitter	Emitter terminal
6	Channel B – Collector	Collector terminal
7	Channel A – Emitter	Emitter terminal
8	Channel A – Collector	Collector terminal

PIN	CONNECTOR: CON2	DESCRIPTION
1	Power supply terminal 1	AC or DC
2	Power supply terminal 2	AC or DC

PIN	CONNECTOR: CON3	DESCRIPTION
RX	Data receive	Input
TX	Data transmit	Output
GND	Ground	0V
Vcc	Supply for UART isolator	3V – 5.5V

PIN	CONNECTOR: CON4
1 & 2	Loop channel D, loop connection
3 & 4	Loop channel C, loop connection
5 & 6	Loop channel B, loop connection
7 & 8	Loop channel A, loop connection
9	Earth terminal

## Known issues

Date	PCB revision	Description	Fix
2024-01-09	Rev 0	Digital outputs silk-screening is in reverse. Channels are labelled in reverse.	Ignore silk-screening for digital outputs on the PCB.



## Features of the detector

### Loop oscillation frequency

Frequency of loop oscillator is primarily defined by the wire loop geometry and the number of loop turns/windings. In order to prevent the cross-talk there is an option to slightly change the frequency of the loop oscillator using the “alternative frequency” feature. Enabling this option will lower the oscillation frequency.

### Detection sensitivity

Sensitivity of each loop channel can be adjusted by pressing the corresponding channel button. Current sensitivity is always displayed on LED bar-graph while the detector is operating.

**Note 1:** Sensitivity can only be changed while detection is not present on current channel.

**Note 2:** Do not restart or power up the detector while holding down all channel buttons at the same time because this will reset the detector to factory settings.

### Slow startup (Warm up)

This option sets sensitivity of each channel to minimum value upon startup, and slowly increases it to match the pre-set target sensitivity. This process is displayed on the bar-graph as rapid blinking of the current sensitivity and its gradual increase toward the pre-set target sensitivity.

### Detect LED mapped to output

The **DETECT** LED normally shows vehicle detection status. Digital outputs (relays) might have a different state during the detector operation (such as when pulsing the output is used instead of **presence output**). If it is required to show the actual state of the digital output then this option can be enabled.

### Delayed Runtime Re-Calibration

If a loop failure of any channel is detected, the detector will attempt to recalibrate it multiple times per second. Recalibration might take a few seconds to complete and in case there is a permanent error this will impair detector operation. If practical, enabling this option will delay the recalibration attempt of the affected channel by a configurable delay of 1 minute to 4 hours. Default value is 1 minute.

### Autotune on startup

If detector has been installed in an environment where interference is present, to skip choosing alternative frequency manually this **experimental** option will try to find the best alternative frequency where least interference is detected.

**Note 1:** This feature is most reliable after the detector has been warmed up to its operating temperature, and then a final reset has been performed.

**Note 2:** When enabled, this feature will slow down the detector startup time.

## Additional signal filtering

If the detector is installed in a location where interference is inevitable or expected, it is desirable to enable additional signal filtering to ensure reliable operation.

**Note:** Additional signal filtering will slightly decrease sensor sensitivity and response time.

## Fail Safe

When detector is reset all outputs will be (and remain) activated until first vehicle is detected. In case vehicle was over the loop while detector was reset (powered up) it is required for the vehicle to leave and another to be detected in order to deactivate the output. This option works only for outputs configured in **presence output** (not outputs that send pulse upon detection) and is usually used to prevent barrier gate closing on a vehicle that was over the loop when power supply was cut.

## Inverted output

This option will invert the output state. Default output state is high impedance when vehicle is not detected.

## Delay output activation

In case channel is set to **presence output**, enabling this option will delay activation of the output for 2 seconds. This value is configurable by PC Configurator to up to 12 seconds.

**Warning:** Enabling this option while **presence output** is disabled will cause output to never be pulsed!

## Blink frequency on startup

Loop oscillator frequency of each channel can be displayed on **DETECT** LED after the detector is reset, if this option is enabled. LED will blink in steps of 10 kHz.

**Example:** if LED blinks 7 times it means that the frequency of loop is between 70 kHz and 79 kHz.

**Note:** When enabled, this feature will slow down the detector startup time drastically.

## PPC – permanent presence canceller

It is possible to configure the detector to automatically cancel-out current detection if vehicle has been parked on the loop for certain amount of time. There are three durations that can be selected: 5 minutes (minimum), 10 minutes (middle) and 20 minutes (maximum). These three values can be fine-tuned using PC configurator software to any value between 1 minute and 4 hours and 15 minutes.

## Detect Stop

Some modes of operation allow using special feature that detects only when vehicle has completely stopped above the loop in order to pronounce (call) a detection.

One scenario where this option would come in handy is in parking lots where there is an exit loop that activates gate barrier to open and let vehicles out but other vehicles also pass over it without wanting to exit the parking lot.

Another scenario is in storage halls for opening automatic doors for forklifts. This option can be used in places where there is not enough room for dedicated loop area for activation of opening of automatic doors. For example, when a forklift wants to enter gate 2, normally it would activate gate 3 and gate 4 as shown in the picture. With Detect Stop option enabled, only the desired gate would open (in this case gate 2). Forklift only needs to stop over gate 2 loop and it would open. Detect Stop option is immune to detect time, so even slow-moving vehicles would not activate it.

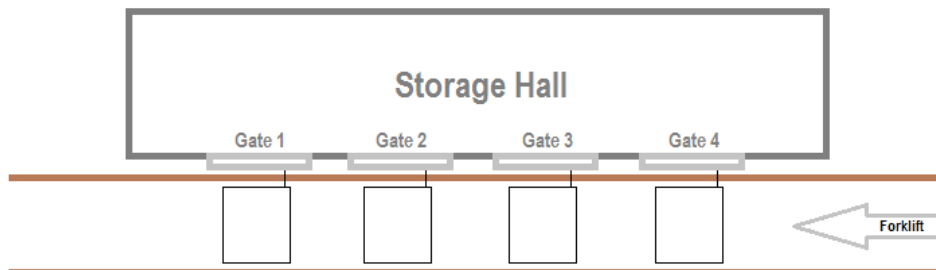

### ASB – Automatic Sensitivity Booster

This option increases sensor sensitivity to maximum upon initial detection. This is usually used to detect trucks and vehicles with trailers if sensor is not already configured to maximum sensitivity. If sensor is already configured to maximum sensitivity, this option is ignored.

### Factory Reset

In order to reset the detector to factory settings, press and hold all 4 channel buttons and restart or power up the detector. This feature is useful if you used the PC configurator software to fine-tune operating parameters, but also made a mistake during choice of parameters.

### PC Configurator Software

Detector can be fine-tuned using the PC Configurator Software (explained in another document). Using this software (or other custom solution following detector's protocol) it is possible to use it for logging vehicle magnetic signature as well as in "logging mode" to receive detector events with timestamps:

- Vehicle detected
- Detected vehicle stop (with detection strength)
- Detected vehicle movement prior stopping
- Detected vehicle movement after stopping
- Detected repeated vehicle stop (with detection strength)
- Vehicle rollaway (vehicle undetected without prior stopping)
- Vehicle undetected (with detection strength)
- Detected passing A → B (or C → D)
- Detected passing B → A (or D → C)
- Detected cancellation of A → B (or C → D) pass
- Detected cancellation of B → A (or D → C) pass
- Going back in A → B (or C → D) direction
- Going back in B → A (or D → C) direction

The PC configurator software can be used to disable detector's DIP switches and use software-based detector configuration. This allows full remote management with options to: read current settings, send new settings, reset the detector and restore to factory settings.

## Configuration of the detector

Configuration of the detector can be done by using DIP switches on the detector or by using the PC Configurator.

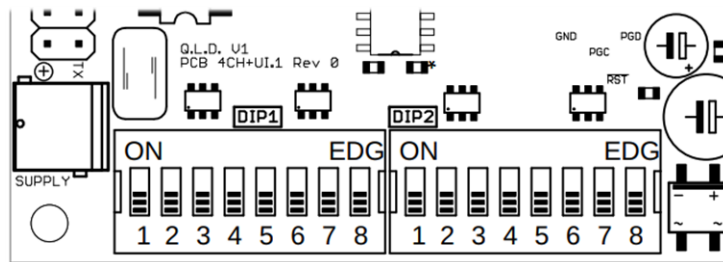

*DIP switches for setting “general detector” and “channel specific” configuration*

The detector's configuration is separated into two types:

1. General configuration
2. Channel specific configuration

**General** configuration is used to set common parameters of the detector, e.g.: which channel is enabled and mode of channel operation (independent channel or directional logic mode), additional signal filtering and so on. **Channel specific** configuration are parameters for each channel individually, such as output types or specific features for that channel.

All configuration is done via DIP switches while the detector is powered on. After changing any configuration, detector needs to be reset in order for changes to be applied.

It is recommended to first set **Channel specific** configuration for each enabled channel and then finally the **General** configuration.

### General configuration

After the detector is restarted, current state of DIP switches is loaded and settings are applied.

#### DIP 1

Switch	Option	Description
1	Channel A enabled	Channel A is enabled
2	Channel B enabled	Channel B is enabled
3	Channel C enabled	Channel C is enabled
4	Channel D enabled	Channel D is enabled
5	A+B Directional Mode	Channels A+B are grouped in directional mode. In case channel A or B are disabled, they will be enabled if this option is enabled.

6	C+D Directional Mode	Channels C+D are grouped in directional mode. In case channel C or D are disabled, they will be enabled if this option is enabled.
7	Reserved	Not used
8	Reserved	Not used

## DIP 2

Switch	Option	Description
1	Additional Signal Filtering	Additional signal filtering is desirable to ensure more reliable detector operation.
2	Blink Frequency on Startup	Option to blink the oscillator frequency upon startup for each channel.
3	Slow Startup (Warm Up)	When enabled, sensitivity of each channel is set to minimum upon startup, and slowly increased to target sensitivity.
4	Autotune on Startup	After the detector has been restarted this experimental feature will automatically try every alternative frequency in order to tune into the one with least environmental interference.
5	A+B Detect Reversing A->B	When enabled, this option will cause relay A to be activated only when vehicle cancels from full passing in travel direction A→B.
6	A+B Detect Reversing B->A	When enabled, this option will cause relay B to be activated only when vehicle cancels from full passing in travel direction B→A.
7	C+D Detect Reversing C->D	When enabled, this option will cause relay C to be activated only when vehicle cancels from full passing in travel direction C→D.
8	C+D Detect Reversing D->C	When enabled, this option will cause relay D to be activated only when vehicle cancels from full passing in travel direction D→C.

## Channel specific configuration

The same DIP switches are used to set operating parameters for each individual channel. This process is done in following steps:

1. Press and hold the button of channel that needs configuring
2. Reset the detector
3. Release the channel button. Bar-graph will display the current DIP configuration for that channel from internal memory
4. Set DIP1 and DIP2 to the desired state and according to the instructions for operating mode in which that channel is set (individual or directional logic)
5. Press and hold the channel button for settings to be saved into internal memory. Bar-graph will display the new DIP configuration

6. To configure next channel: press the button of another channel
  - a. Go to step 3
7. When all enabled channels are configured, set the DIP1 and DIP2 to **General** configuration parameters and restart the detector

**Note:** It is possible to skip already configured channels using this method.

### Operating Mode: “Independent channels”

In this operating mode a channel operates independently from other channels.

#### DIP 1

Switch	Option	Description
1	Alternative loop oscillator frequency +1	Change loop oscillator frequency in order to avoid cross-talk with adjacent detectors.
2	Alternative loop oscillator frequency +2	Further increase the amount of alternative loop oscillator frequency.
3	PPC – Permanent Presence Cancellor +1	When enabled, PPC will be executed after 5 minutes.
4	PPC – Permanent Presence Cancellor +2	When enabled, PPC will be executed after 25 minutes. <b>Note 1:</b> If enabled together with “PPC +1”, it will be executed after 35 minutes. <b>Note 2:</b> These times are configurable with PC Configurator.
5	Presence Output	If enabled, output will be activate as long as there is a detection. If disabled, output will be pulsed upon detection.
6	Extended Output Pulse	If output is set to pulse, this will extend the pulse from default 250ms to 500ms. <b>Note:</b> These are configurable with PC Configurator.
7	Delay Output Activation	If enabled, output will be activated after a pre-set time of 2.5 seconds. <b>Warning:</b> Enabling this option while <b>presence output</b> is disabled will cause output to never be pulsed! <b>Note:</b> This length is configurable with PC Configurator.
8	Inverted Output	If enabled, output will be inverted.

#### DIP 2

Switch	Option	Description
1	ASB - Automatic Sensitivity Booster	Boosting sensitivity to maximum upon detection. This option is ignored in case channel is already set to maximum sensitivity.
2	Detect Stop	Detecting only stopped vehicles.
3	Fail Safe	Fail Safe option.

4	Detect LED Mapped to Output	When enabled, the <b>DETECT</b> LED will show the state of output instead of detection state.
5	Pulse on Entry	When enabled while <b>presence output</b> is disabled, output pulse will be issued upon detect, otherwise output pulse will be issued on un-detect event.
6	Delay Runtime Re-Calibration	When enabled, runtime re-calibration of this loop channel will be delayed. Default value is 1 minute. <b>Note:</b> This delay is configurable with PC Configurator.
7	Reserved	Not used
8	Reserved	Not used

### Operating Mode: “Directional Logic A+B and/or C+D”

In this operating mode both channels of a group are enabled and they are linked together using directional logic.

For group of channels A+B, this operating mode is used to distinguish vehicles passing in A→B or B→A direction, usually in conjunction with free parking space counters. It is also possible to detect special conditions such as cancellation of a pass (vehicle started passing A→B but cancelled and went back).

The same logic applies to the other group of channels C+D.

**Note:** It is important to note that distance between A and B loops must be short enough so that vehicle is above both loops at some point. This is shown in the image below:

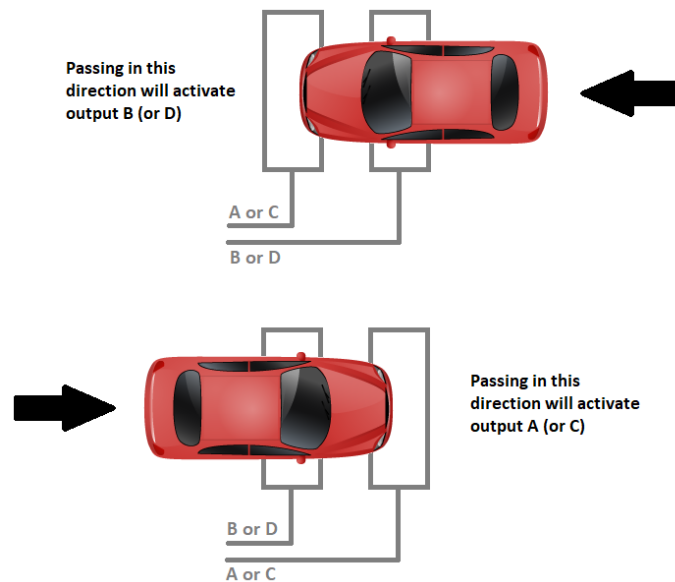

### DIP 1

Switch	Option	Description
1	Alternative loop oscillator frequency +1	Change loop oscillator frequency in order to avoid cross-talk with adjacent detectors.

2	Alternative loop oscillator frequency +2	Further increase the amount of alternative loop oscillator frequency.
3	<i>Ignored</i>	<i>Ignored</i>
4	<i>Ignored</i>	<i>Ignored</i>
5	<i>Ignored</i>	<i>Ignored</i>
6	Extended Output Pulse	This will extend the pulse from default 250ms to 500ms. <b>Note:</b> These are configurable with PC Configurator.
7	<i>Ignored</i>	<i>Ignored</i>
8	Inverted Output	If enabled, output will be inverted.

## DIP 2

Switch	Option	Description
1	ASB - Automatic Sensitivity Booster	Boosting sensitivity to maximum upon detection. This option is ignored in case channel is already set to maximum sensitivity.
2	<i>Ignored</i>	<i>Ignored</i>
3	<i>Ignored</i>	<i>Ignored</i>
4	Detect LED Mapped to Output	When enabled, the DETECT LED will show the state of output instead of detection state.
5	<i>Ignored</i>	<i>Ignored</i>
6	Delay Runtime Re-Calibration	When enabled, runtime re-calibration of this loop channel will be delayed by 1 minute. <b>Note:</b> This delay is configurable with PC Configurator.
7	Reserved	Not used
8	Reserved	Not used

### Operating mode: “Combination of directional logic and independent channels”

The detector can be configured to work in a way that one group (A+B or C+D) is used in directional logic configuration and remaining two channels of the other group as independent channels.

To achieve this, simply follow instructions in **General** configuration.



## Additional information

### Channel Outputs

Channel outputs are optically isolated open-collector outputs by utilizing **LTV-247**, with the following characteristics:

Parameter	Symbol	Rating	Unit
Collector - Emitter Voltage	$V_{CEO}$	80	V
Emitter - Collector Voltage	$V_{ECO}$	7	V
Collector Current	$I_C$	50	mA

*Absolute maximum ratings for channel outputs*

If required, connecting relays to outputs is also possible. Connected relays require their own drivers and power supply. Schematics for connecting a relay to one output can be accomplished as:

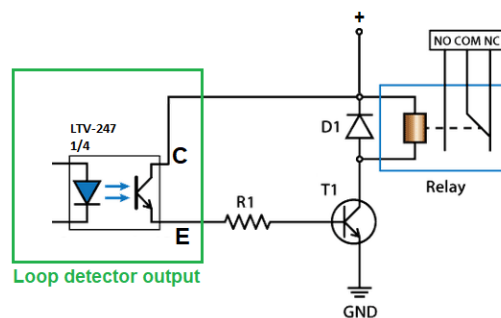

*Example of connecting a relay to one of the outputs of LTV-247 (emitter follower configuration)*

### PC Configurator

If the detector variant supports only UART TTL for communication, connection with PC can be done via **USB<->UART** driver, such as:



*USB<->UART TTL converter*

PC Configurator software is available for download at this address: <https://github.com/elektronika-ba/quad-loop-detector-configurator>

Quad Channel Inductive Loop Vehicle Detector - www.elektronika.ba

File Device Help

Connect/Disconnect (F1) Read from device (F2) Program device (F3) Return to running mode (F4) Restart CPU (F5) Factory reset (F10)

**Main configuration**

Sampling speed  
Sensitivity levels  
Filtering levels  
Output pulse durations  
Permanent presence cancellation  
Detect stop  
Drift compensation during detection  
Miscellaneous  
Event viewer  
Signal analysis

**Main configuration**

General DIPs Channel DIPs

Quick presets: - Choose preset -  Use software DIPs (ignore DIP settings on device)

DIP 1

- 1. Channel A Enabled
- 2. Channel B Enabled
- 3. Channel C Enabled
- 4. Channel D Enabled
- 5. A+B Directional Mode
- 6. C+D Directional mode
- 7. - reserved -
- 8. - reserved -

DIP 2

- 1. Additional Signal Filtering
- 2. Blink Frequency on Startup
- 3. Slow Startup (Warm Up)
- 4. Autotune on Startup
- 5. A+B Detect Reversing A->B
- 6. A+B Detect Reversing B->A
- 7. C+D Detect Reversing C->D
- 8. C+D Detect Reversing D->C

Use this panel to configure the device configuration when software DIPs is enabled. If your device does not have hardware DIPs, make sure you enable software DIPs checkbox at the top of this screen.  
Note: These settings take effect only when Software DIPs are used.

If you want to read device's current configuration, click the button:

v1

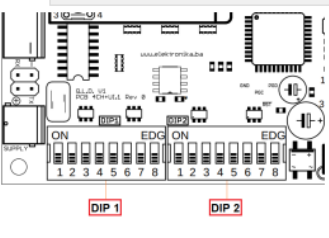

UART speed

Device's UART port speed: 115200

After changing UART port speed in device and resetting it, do not forget to open File -> Connection settings, and set the same port speed.

2024-12-15 17:45:45 Status: Disconnected [Loop A: 0.00 kHz](#) [Loop B: 0.00 kHz](#) [Loop C: 0.00 kHz](#) [Loop D: 0.00 kHz](#) State: Running

### PC Configurator

## Problem diagnostics

Symptom	LED State	Description										
Everything works but LEDs are flickering	<b>ERROR LED:</b> <i>irrelevant</i>  <b>DETECT LED:</b> <i>irrelevant</i>	<b>This is normal</b> behaviour due to the multiplexing of the LEDs. If application permits, you can reconfigure the detector for faster sampling using the PC Configurator.										
Sensor repeatedly produces random detections even without vehicle over the loop, or LED bar-graph blinks erratically	<b>ERROR LED:</b> <i>irrelevant</i>  <b>DETECT LED:</b> <i>irrelevant</i>	<b>Potential problems:</b> damaged loop wiring, bad loop contact, loop moving in ground, cross-talk with adjacent detectors or bad detector installation.  <b>Possible solution:</b> try changing loop oscillator frequency, filtering level or sensitivity level, try placing detector in a sealed plastic box to avoid air flowing over the detector components.										
Channel(s) does not detect	<b>ERROR LED:</b> Yes  <b>DETECT LED:</b> No	Press the channel button to read what kind of error is present on that channel: <table border="1" data-bbox="906 875 1390 1496"> <thead> <tr> <th>DETECT LED blinks</th> <th>Error description</th> </tr> </thead> <tbody> <tr> <td>2</td> <td>Frequency below minimum allowed of problem with oscillator - check loop wiring and connections or treat error as number 3 (see below).</td> </tr> <tr> <td>3</td> <td>Frequency below minimum allowed. Change number of loop turns/windings or choose alternative frequency using DIP settings.</td> </tr> <tr> <td>4</td> <td>Frequency above maximum allowed. Change number of loop turns/windings or choose alternative frequency using DIP settings.</td> </tr> <tr> <td>5</td> <td>Frequency not stable. Please wait and detector will recalibrate as soon as oscillator stabilizes.</td> </tr> </tbody> </table>	DETECT LED blinks	Error description	2	Frequency below minimum allowed of problem with oscillator - check loop wiring and connections or treat error as number 3 (see below).	3	Frequency below minimum allowed. Change number of loop turns/windings or choose alternative frequency using DIP settings.	4	Frequency above maximum allowed. Change number of loop turns/windings or choose alternative frequency using DIP settings.	5	Frequency not stable. Please wait and detector will recalibrate as soon as oscillator stabilizes.
DETECT LED blinks	Error description											
2	Frequency below minimum allowed of problem with oscillator - check loop wiring and connections or treat error as number 3 (see below).											
3	Frequency below minimum allowed. Change number of loop turns/windings or choose alternative frequency using DIP settings.											
4	Frequency above maximum allowed. Change number of loop turns/windings or choose alternative frequency using DIP settings.											
5	Frequency not stable. Please wait and detector will recalibrate as soon as oscillator stabilizes.											
ERROR LED is ON but sensor works fine	<b>ERROR LED:</b> Yes  <b>DETECT LED:</b> <i>irrelevant</i>	Even though sensor works properly, ERROR LED is ON to indicate that an error was present. Press the channel button to show the error on DETECT LED.										

## Document History

Date	Document version	Description
2024-12-18	20241215-draft	Initial version.
2025-01-09	20250109-Update1	Changed pinout of digital outputs, updated errata.