

# How to build a simple solid state Tesla Coil

While I was in search of something that could satisfy my desire to build up a working Tesla Coil, I met with the many copies of a simple circuit. All of these were the same except some of them offered different values about resistors. When I had the chance, (in fact gained a small flyback transformer) soldered the parts together, applied the voltage and had 2cm. long violet sparks at the first test drive.

Although the circuit was so simple thus seemed should work with no problems, I realized one of my transistors became very hot quickly while the other was somehow wormed. To investigate the problem, I measured the collector currents of transistors seperately and found that one of them was conducting about %85 of the the total current. According to my digital avometer, the hFE (current gain) value of the more conducting transistor was 180 and the other one's was a little different: 160.

This little difference (only %12) made the circuit asymmetric and decreased the performance. Just to learn how much an invidual transistor could drive the transformer, I disconnected one of them each time and found that only one transistor was enough to operate the circuit. In fact connecting the second transistor was making the circuit unstable and decrease voltage output.

So I decided to start with a single transistor circuit and optimize it. Dual transistor circuit required identical transistors and also identical primary and feedback windings that have the same resistance (capaticance / inductance) values. 2N3055 or equivalent power transistors are not so cheap to buy a lot and not many of the sellers would allow you to select identical pairs with your multimeter at their shop. Since it's impractical to measure winding inductances, you'll appreciate why I offer you a single transistor solid state Tesla Coil as a starting point:

- # Input voltage limit depends on your transformer and transistor. Your flyback transformer won't be able to exceed a certain voltage determined by the size and isolation level of it.
- # Resistors should have enough wattage to stay alive. Just to be sure, prefer 5W for both R1 and R2.

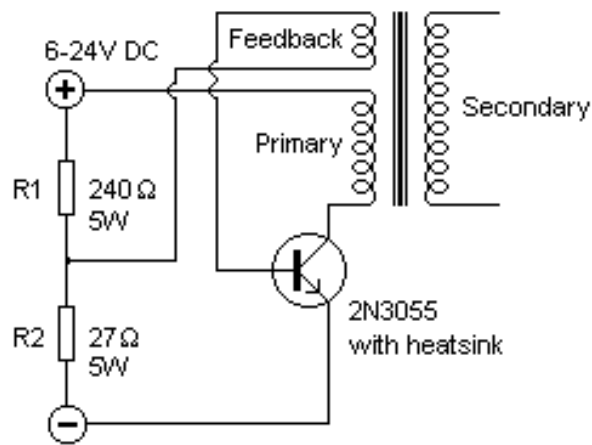

- # 2N3055 should have mounted on a large heatsink that can absorb enough heat at selected operating voltage/current.
- # Due to varieties in transistors' current gain ratios, you may improve performance by adjusting the number of feedback turns. Most transistors need more than 2 turns.
- # Grounding the secondary's innermost lead will cause many problems: it will easily shock you since you're grounded too, the transformer will show internal sparkings that will heat it up, decrease voltage output, and even destroy itself within seconds ...

Be sure that you really understood the basic operating principle of this circuit. If there was no feedback winding, the transistor would conduct a steady current determined by the values of R1 and R2. But now the circuit is dynamic: It will oscillate on a natural frequency that puts your transformer in a resonance activity resulting in enormous voltage gain. Of course without any tuning attempt you can't expect the system running on the right resonance frequency. But it is not so important that your transformer would already be running in it's limits in the given voltage range. Such a tuning is more critical when you deal with a real Tesla Coil. If you want to learn what 'Resonance' means in this case, you can find very detailed explanations over the net or in electronics books about this phenomena.

The heart of the circuit is a ferrit-core flyback transformer that you can find in an old black-white TV or a malfunctioned monochrome monitor. Even though color TV and monitors have stronger flybacks, their secondaries contain additional windings and built in diodes usually whole coated with plastic that makes them hard to deal with and just because the diodes cause inconsistency on output voltage and voltage multipliers formed with capacitors and these diodes create dangerous voltage + current + frequency combinations I do not recommend this ones at the beginning. Find the simplest, single wound secondary transformer. Check out if it's secondary is ok with an analog multimeter. If there is a resistance (about a few hundred ohms) then you may think it is not burned (yet). Here is what it might look like:

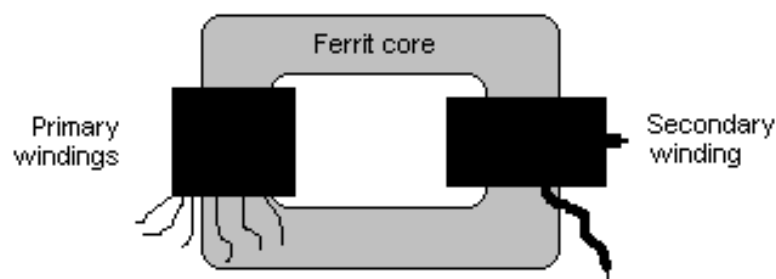

Second step is the removal of the primary windings. An old but sharp enough knife

would do this so quick; just cut them and clean the winding area.

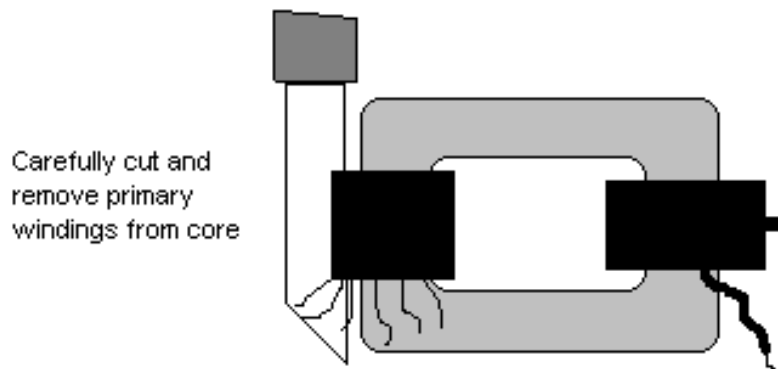

Now you only have the secondary, although it looks innocent, is capable to produce thousands of volts if you wind 5-6 turns of wire on core and then connect and disconnect it to the power supply rapidly to watch the secondary convert your high current / low voltage input to low current / high voltage output. There's no need to remind you not to touch secondary terminals while doing this. Otherwise you'll get nasty shocks on your fingertips as a natural warning!

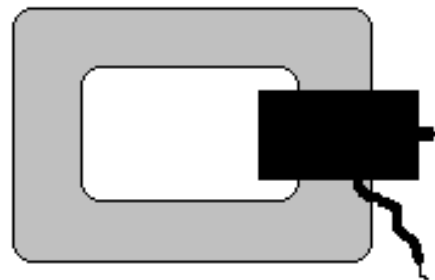

Now you only have the secondary ...

What the transistor will do is just to make this open-close loops automatically and continuous. When you apply the power, circuit will start to operate on a frequency determined by the winding inductance, capacitance, and ohmic resistance of primary, secondary's load status, composition and size of the ferrit core, length and position of the connection cables, junction capacity of the transistor, and many more as you can think of !

To form low inductance primary; wind 5 turns of enameled 18AWG wire (1mm diameter) on the core. Secure it with tape or glue at your choice.

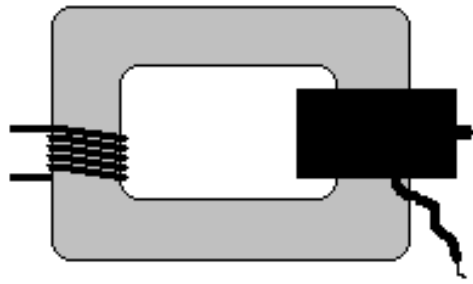

Wind on primary

To form feedback winding use 22AWG wire (0.64mm diameter) and wind 2 turns (or 3-4 turns depending on your transistor's  $H_{fe}$ ) then secure it.

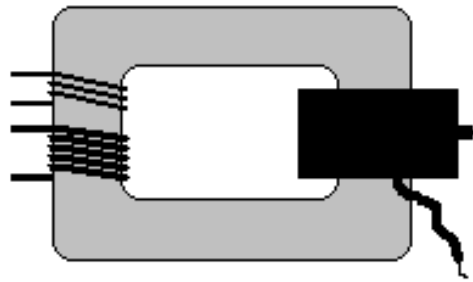

And then feedback ...

Now the mechanism is ready. Connect your resistors and transistor to this transformer system as in the circuit diagram. Do not forget to mount your transistor to a heatsink, otherwise it may be damaged after a very short period of operating time.

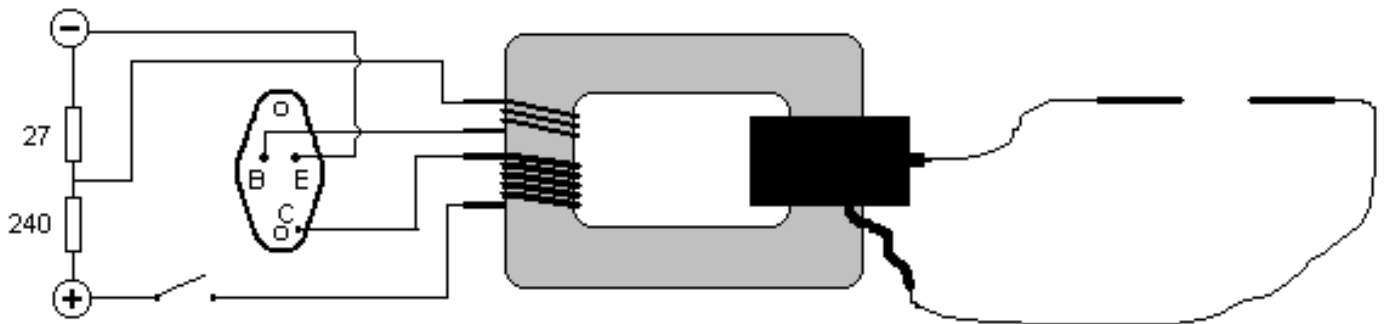

Ready to go?

The value for R1 is for 24-32 volts operation. You may replace it with a lower value like 110 ohms for lower voltages. But 240 ohms will operate the circuit without any problems. As the input voltage rises the power consumption on R2 (27 ohms) increases. Although it seems won't become hot as much as R1 according to ohms law, current inducted on feedback winding uses R2 to reach the ground and this should be added to the calculation. So check it's temperature and use a higher wattage one if necessary.

Be sure that your power supply is capable of giving the 2-3 amps current as circuit will take. Set two cables in clearance of about 1mm at their tips to observe high voltage output from the secondary leads. This is an initial gap length to be sure. Please use a push button type switch since it would stop the circuit as you take your finger away. This is a legitimate precaution and the circuit should never be operated while it is constantly connected to the power supply. As you understood the security reasons well, apply the power by pressing the button. Now you should be able to see the sparkings. If not, and your multimeter shows that the circuit is already dragging 1-2 amps (or more) current then it's just the feedback leads you have to reverse. Now your mini monster should be working.

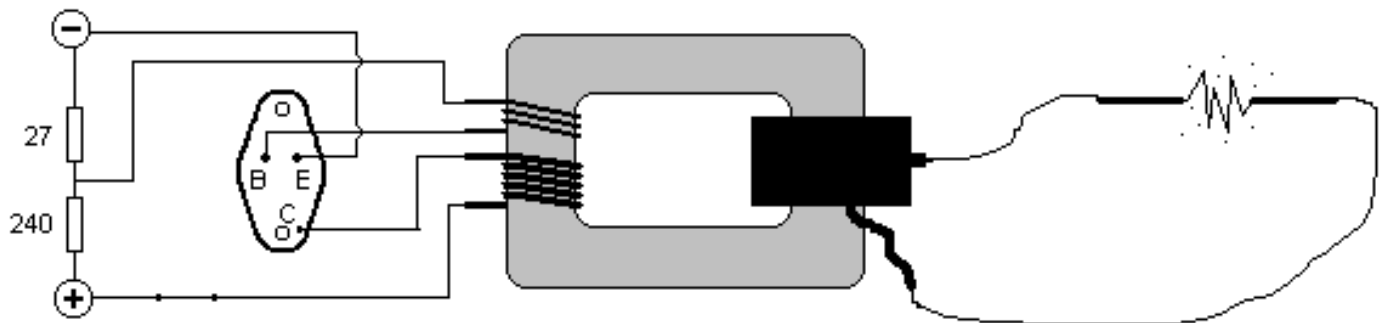

Yes, it's working!

Use cables with very thick isolations if you are going to pick them and play around. Even when they are very isolated looking, cables can leak electricity since they are capacitively conductive at these much high frequencies. So your fingers can be burnt without any pain. Prefer to hold them by an isolated pliers or something like that. Better, have a rubber glove. In fact, nothing (even mica isolators) behaves as an insulator in this case. Be careful! Be very careful!! Always be in a mood like you're in the unknown deep ocean of the mysteries of the electricity. Again; be careful!!!