

Dual Channel Inductive Loop Vehicle Detector, PCB v1.3

FW: v1

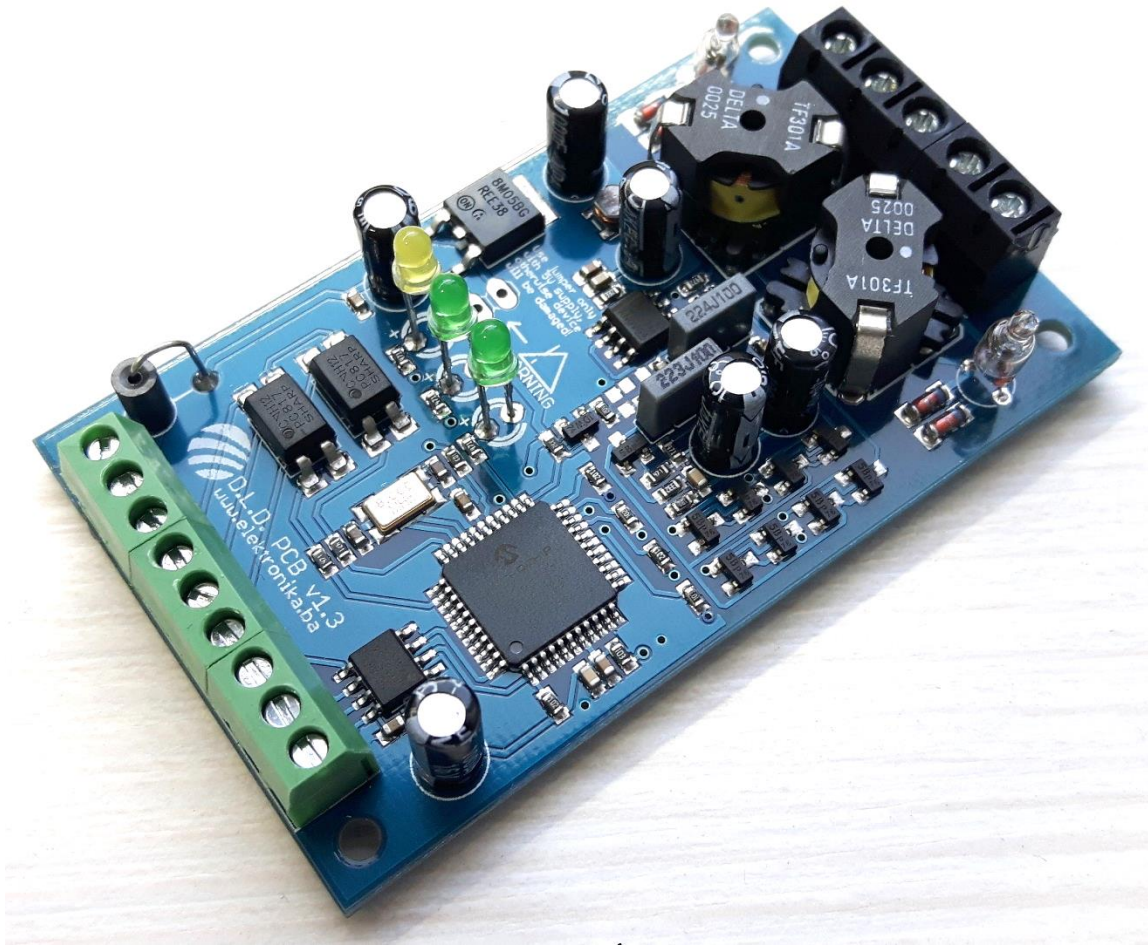

Dual Channel Inductive Loop Vehicle Detector, PCB v1.3

Technical details

Number of operating modes:	4 (Single Channel, Dual Channel Independent, Directional Logic, Speed Trap)
Tuning:	Automatic
Detection type:	Presence/Pulse
Presence time:	Adjustable in 3 steps
Pulse duration:	250 ms / 500 ms
Signal filtering:	Adjustable in 2 steps (NORMAL, HIGH)
Loop inductance:	20 μ H – 1000 μ H
Frequency range:	20 kHz – 145 kHz
Frequency selection:	2 combinations (LOW, HIGH)
Sensitivity:	Maximum 0.0025% $\Delta f/f$, adjustable in 8 steps
Detection speed:	10 ms by default, adjustable
Start-up time:	~ 1 second per channel
Power supply:	7-14 V DC / 5 V DC with jumper
Current consumption:	~ 0.015 A
Temperature range:	-35°C – 120°C
Sensor protection:	Galvanic isolation + gas discharge tube for lightning protection
Dimensions:	7,5cm x 4,5cm

Contents

- Description 3
- Configuring the device 4
 - Loop oscillator frequency 4
 - Additional signal filtering 4
 - Fail Safe 4
 - PPC – permanent presence canceller 4
 - Detect Stop option 4
 - ASB – Automatic Sensitivity Booster 5
- Device Operating Mode 5
 - Operating Mode: „Single Channel (only A)“ 5
 - Operating Mode: „Dual Channel Independent A & B“ 6
 - Operating Mode: „Dual Channel Directional Logic A + B“ 7
 - Operating Mode: „Speed Trap A + B“ 9
- Problem diagnostics 11

Description

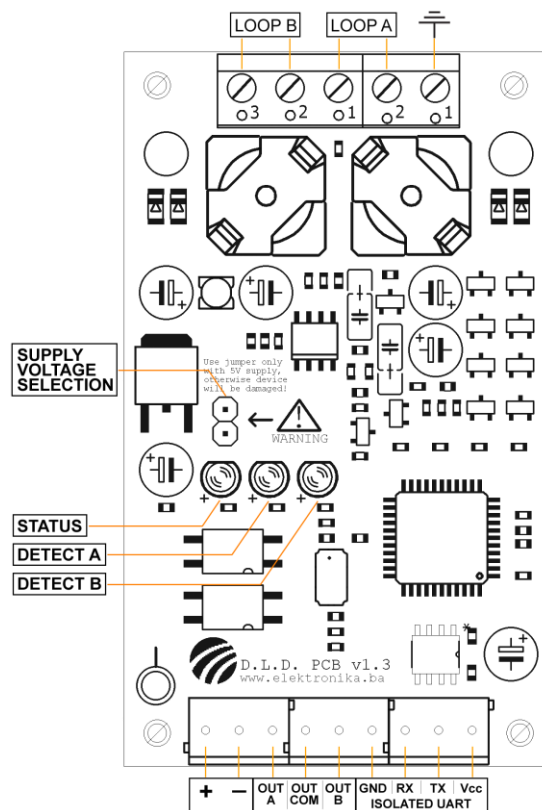

Sensor components

Outputs (OUT)	Optocoupler collector outputs (NPN) OUT A – Channel A optocoupler output OUT COM – Common for both channel outputs (emitters) OUT B – Channel B optocoupler output
Power (+ and -)	7 – 14 V DC without jumper installed 5.0 V DC with jumper installed WARNING: When “Supply voltage selection” jumper is installed, and voltage > 5.0V DC is supplied, the device will be permanently damaged! Note the maximum voltage that device can accept.
Loop (A & B)	Input for connecting the wire loop (coil) 20 uH – 1000 uH
Isolated UART	4-pin connector for connecting device to PC for detailed configuration (fine-tuning). UART interface is isolated and external power supply must be applied (usually 3V3 or 5V). GND – Ground for isolated interface power supply RX – data input TX – data output Vcc – Positive power supply for isolated interface (usually 3V3 or 5V)
Status and Detect LEDs	LEDs for displaying current device operating state and detection events. Status LED blinks in ½ Hz interval when fully operational, and is

	constantly ON in case there is a fault in memory
--	--

Sensor components description

Configuring the device

The device is configured and set up using the PC Configurator Software. All references to DIP switches further in document are to the checkboxes that are found in the PC Configuration Software.

This tool is described in detail in another document.

Loop oscillator frequency

Frequency of loop oscillator is primarily defined by the wire loop geometry and the number of loop turns/windings. In order to prevent the *cross-talk* there is an option to slightly change the frequency of the loop oscillator using the “alternative frequency” option.

Additional signal filtering

If the device is installed in a location where interference is inevitable or happens often, it is desirable to enable additional signal filtering to ensure reliable operation. It is important to note that additional signal filtering will slightly decrease sensor sensitivity and response time.

Fail Safe

When device is reset both relays will be (and remain) activated until first vehicle is detected. In case vehicle was over the loop while device was reset (powered up) it is required for the vehicle to leave and another to be detected in order to deactivate both relays. This option works only for relays configured to detect vehicle presence (not relays that send pulse upon detection) and is usually used to prevent barrier gate closing on vehicle that was over the loop when power supply was cut.

PPC – permanent presence canceller

It is possible to configure the device to automatically cancel-out current detection if vehicle has been parked on the loop for certain amount of time. There are three durations that can be selected: 5 minutes (minimum), 10 minutes (middle) and 20 minutes (maximum). These three values can be fine-tuned using PC configurator software to any value between *1 minute* and *4 hours and 15 minutes*.

Note: Some modes of device operation can only choose between *infinity* and the maximum programmed value.

Detect Stop option

Some modes of operation allow using special feature that detects only when vehicle has been completely stopped above the loop in order to pronounce (call) a detection.

One scenario where this option would come handy is in parking lots where there is an exit loop that activates gate barrier to open and let vehicles out but other vehicles also pass over it without wanting to exit the parking lot.

Another scenario is in storage halls for opening automatic doors for forklifts. This option can be used in places where there is not enough room for dedicated loop area for activation of opening of automatic doors. For example, when a forklift wants to enter gate 2, normally it would activate gate

3 and gate 4 as shown in the picture. With Detect Stop option enabled, only the desired gate would open (in this case gate 2). Forklift only needs to stop over gate 2 loop and it would open. Detect Stop option is immune to detect time, so even slow-moving vehicles would not activate it.

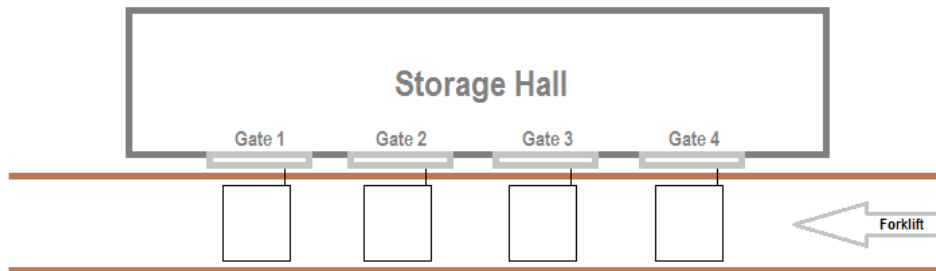

ASB – Automatic Sensitivity Booster

This option increases sensor sensitivity to maximum upon initial detection. This is usually used to detect trucks and vehicles with trailers if sensor is not already configured to maximum sensitivity. If sensor is already configured to maximum sensitivity, this option is ignored.

Device Operating Mode

DIP 1 (switch 1)	DIP 1 (switch 2)	Operating Mode
OFF	OFF	Single Channel (only A)
ON	OFF	Dual Channel Independent A & B
OFF	ON	Dual Channel Directional Logic A + B
ON	ON	Speed Trap A + B

Operating modes

Operating Mode: „Single Channel (only A)“

In this operating mode channel B is deactivated so there is no need to connect a loop to “LOOP B” contacts. In this mode both relays are connected to channel A, and can be configured individually. DIP settings for this operating mode are defined in following tables:

DIP 1

Switch	Option	Description
3	<i>Reserved</i>	<i>Not used</i>
4	Alternative loop oscillator frequency	Change loop oscillator frequency in order to avoid cross-talk with adjacent detectors.
5	Additional signal filtering	Additional signal filtering is desirable to ensure more reliable device operation.
6	Fail Safe	Presence relays will be activated upon start up until first

		detection occurs.
7	ASB – Automatic Sensitivity Booster	Boosting sensitivity to maximum upon detection. This option is ignored in case device is already set to maximum sensitivity.
8	Detect Stop A	Detecting only stopped vehicles for relay A.

DIP 2

Switch	Option	Description																									
1	Relay A type	When enabled, relay will work in “presence” mode (ON while detection is present). When disabled, relay is in “pulse” mode and will only issue a pulse, as defined with next two switches.																									
2	Relay A extended pulse	When relay is in “pulse” mode this option will extend the relay pulse to 500 ms instead of 250 ms when this option is disabled. Durations of these pulses can be fine-tuned using PC configurator software.																									
3	Relay A condition	When in “pulse” mode and when enabled, relay pulse will be issued upon detect, else relay pulse will be issued on un-detect event.																									
4	Relay B type	<i>See switch 1</i>																									
5	Relay B extended pulse	<i>See switch 2</i>																									
6	Relay B condition	<i>See switch 3</i>																									
7 and 8	PPC – Permanent Presence Cancellor	<table border="1"> <thead> <tr> <th>7</th> <th>8</th> <th>Time</th> <th>Level</th> <th>Description</th> </tr> </thead> <tbody> <tr> <td>OFF</td> <td>OFF</td> <td>Infinity</td> <td>Disabled</td> <td>Device will remain in detected state until vehicle leaves the loop</td> </tr> <tr> <td>ON</td> <td>OFF</td> <td>5 min</td> <td>Minimum</td> <td>After this time expires the device will cancel-out the detection and will be ready to accept new detections. After the parked vehicle finally leaves the loop, device will soon be able to detect next vehicle.</td> </tr> <tr> <td>OFF</td> <td>ON</td> <td>10 min</td> <td>Middle</td> <td><i>--/ same description as above /--</i></td> </tr> <tr> <td>ON</td> <td>ON</td> <td>20 min</td> <td>Maximum</td> <td><i>--/ same description as above /--</i></td> </tr> </tbody> </table> <p>Durations of these pre-defined times can be fine-tuned using PC configurator software.</p>	7	8	Time	Level	Description	OFF	OFF	Infinity	Disabled	Device will remain in detected state until vehicle leaves the loop	ON	OFF	5 min	Minimum	After this time expires the device will cancel-out the detection and will be ready to accept new detections. After the parked vehicle finally leaves the loop, device will soon be able to detect next vehicle.	OFF	ON	10 min	Middle	<i>--/ same description as above /--</i>	ON	ON	20 min	Maximum	<i>--/ same description as above /--</i>
7	8	Time	Level	Description																							
OFF	OFF	Infinity	Disabled	Device will remain in detected state until vehicle leaves the loop																							
ON	OFF	5 min	Minimum	After this time expires the device will cancel-out the detection and will be ready to accept new detections. After the parked vehicle finally leaves the loop, device will soon be able to detect next vehicle.																							
OFF	ON	10 min	Middle	<i>--/ same description as above /--</i>																							
ON	ON	20 min	Maximum	<i>--/ same description as above /--</i>																							

Operating Mode: „Dual Channel Independent A & B“

In this operating mode both channels are independent. Relay A is linked to channel A and relay B is linked to channel B. If, for example, an error happens in channel A, channel B continues to operate normally.

DIP 1

Switch	Option	Description
3	<i>Reserved</i>	<i>Not used</i>
4	Alternative loop oscillator frequency A	Change loop oscillator frequency in order to avoid cross-talk with adjacent detectors.
5	Alternative loop oscillator frequency B	Change loop oscillator frequency in order to avoid cross-talk with adjacent detectors.
6	Additional signal filtering for A & B	Additional signal filtering is desirable to ensure more reliable device operation. Note: This option is for channel A and B at the same time.
7	ASB – Automatic Sensitivity Booster A & B	Boosting sensitivity to maximum upon detection. This option is ignored in case device is already set to maximum sensitivity. Note: This option is for channel A and B at the same time.
8	PPC – Permanent Presence Cancellor A & B	When enabled, PPC will be executed after maximum PPC level programmed (20 minutes by default).

DIP 2

Switch	Option	Description
1	Detect Stop A	Detecting only stopped vehicles at channel A.
2	Detect Stop B	Detecting only stopped vehicles at channel B.
3	Fail Safe A	Fail Safe option enabled for channel A.
4	Fail Safe B	Fail Safe option enabled for channel B.
5	Relay A type	When enabled, relay will work in “presence” mode (ON while detection is present). When disabled, relay is in “pulse” mode and will only issue a pulse, as defined with next two switches.
6	Relay B type	<i>--/ same description as above, but for channel B /--</i>
7	Relay A & B extended pulse	When relay is in “pulse” mode this option will extend the relay pulse to 500 ms instead of 250 ms when this option is disabled. Durations of these pulses can be fine-tuned using PC configurator software. Note: This option is for channel A and B at the same time.
8	Relay A & B condition	When in “pulse” mode and when enabled, relay pulse will be issued upon detect, else relay pulse will be issued on un-detect event. Note: This option is for channel A and B at the same time.

Operating Mode: „Dual Channel Directional Logic A + B“

In this operating mode both channels are enabled but they are linked together using directional logic. This operating mode is used to distinguish vehicles passing in A→B or B→A direction, usually in conjunction with free parking spot counter. It is also possible to detect special conditions such as

cancellation of pass (vehicle started passing A→B but cancelled and went back).

Note: It is important to note that distance between A and B loops must be short enough so that vehicle is above both loops at some point. This is showed in the image bellow:

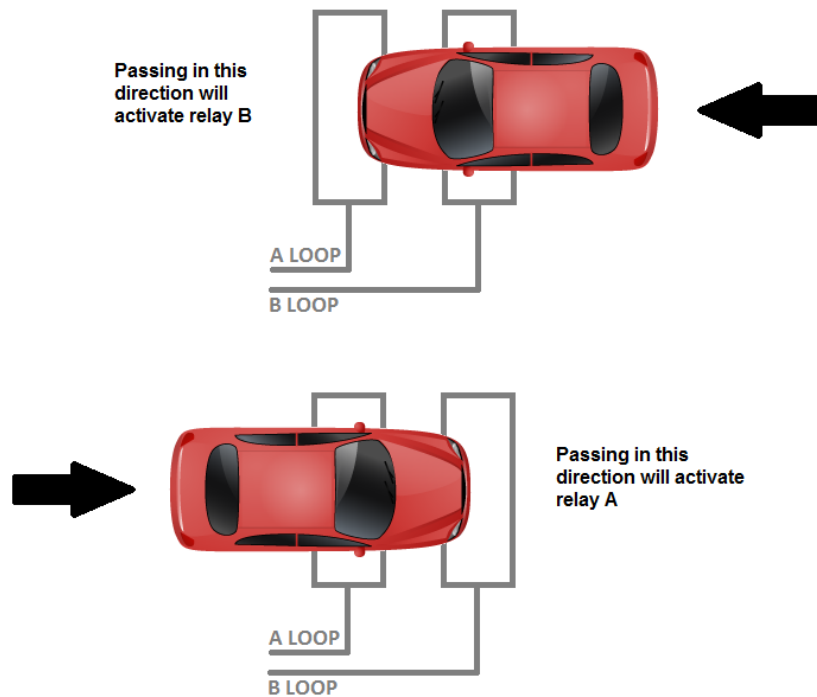

DIP 1

Switch	Option	Description
3	Reserved	Not used
4	Alternative loop oscillator frequency A	Change loop oscillator frequency in order to avoid cross-talk with adjacent detectors.
5	Alternative loop oscillator frequency B	Change loop oscillator frequency in order to avoid cross-talk with adjacent detectors.
6	Additional signal filtering for A & B	Additional signal filtering is desirable to ensure more reliable device operation. Note: This option is for channel A and B at the same time.
7	ASB – Automatic Sensitivity Booster A & B	Boosting sensitivity to maximum upon detection. This option is ignored in case device is already set to maximum sensitivity. Note: This option is for channel A and B at the same time.
8	Relay A & B extended pulse	When relay is in “pulse” mode this option will extend the relay pulse to 500 ms instead of 250 ms when this option is disabled. Durations of these pulses can be fine-tuned using PC configurator software. Note: This option is for channel A and B at the same time.

DIP 2

Switch	Option	Description
--------	--------	-------------

1	Detection of pass cancellation A→B	When enabled, this option will cause relay A to be activated only when vehicle cancels from full passing in travel direction A→B.
2	Detection of pass cancellation B→A	When enabled, this option will cause relay B to be activated only when vehicle cancels from full passing in travel direction B→A.
3	Reserved	Not used
4	Reserved	Not used
5	Reserved	Not used
6	Reserved	Not used
7	Reserved	Not used
8	Reserved	Not used

Operating Mode: „Speed Trap A + B“

In this operating mode both channels are in use. It is possible to measure speed in both directions. Distance between loops A and B is crucial and should match the distance programmed in the device. By default, this distance is configured to 200cm (2m). In case where it is required to change the distances between loops please use PC configurator software. It is also very important that both loops have the same shape so that they detect vehicles at the same position.

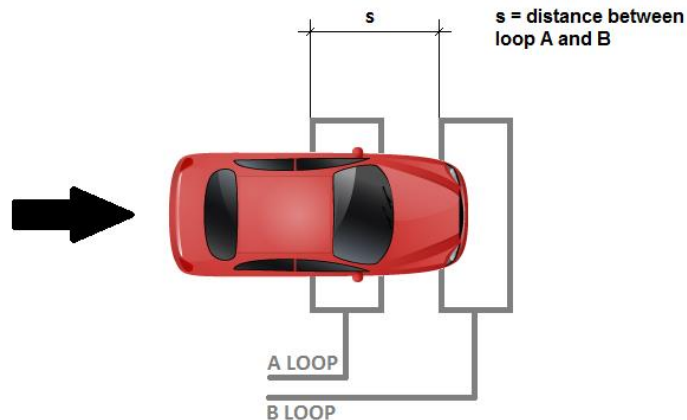

After the sensor measures the speed, it will activate relay A or relay B depending on configured speed limit. Speed limit configuration is done by using DIP switches. If the measured vehicle speed is under or equal to configured speed limit, relay A will be activated. For over-speeding events, relay B is activated.

Measured vehicle speed can be viewed using PC configurator software.

DIP 1

Switch	Option	Description
3	Reserved	Not used

4	Alternative loop oscillator frequency A	Change loop oscillator frequency in order to avoid cross-talk with adjacent detectors.
5	Alternative loop oscillator frequency B	Change loop oscillator frequency in order to avoid cross-talk with adjacent detectors.
6	Additional signal filtering for A & B	Additional signal filtering is desirable to ensure more reliable device operation. Note: This option is for channel A and B at the same time.
7	Relay A & B extended pulse	When relay is in “pulse” mode this option will extend the relay pulse to 500 ms instead of 250 ms when this option is disabled. Durations of these pulses can be fine-tuned using PC configurator software. Note: This option is for channel A and B at the same time.
8	Speed is in [mph]	Speed limit configured with DIP 2 switches is in [mph] units instead of [km/h].

DIP 2

Switch	Option	Description
1	Speed +5	Speed limit is increased by 5 [km/h] or [mph]
2	Speed +10	Speed limit is increased by 10 [km/h] or [mph]
3	Speed +20	--/ same description as above, but for different value /--
4	Speed +30	--/ same description as above, but for different value /--
5	Speed +40	--/ same description as above, but for different value /--
6	Speed +50	--/ same description as above, but for different value /--
7	Speed +60	--/ same description as above, but for different value /--
8	Speed +70	--/ same description as above, but for different value /--

Example of speed limit configured to 50 km/h:

DIP 1 (switch 8) is OFF (speed is in [km/h] unit)

DIP 2 (switch 6) is ON (+50)

Example of speed limit configured to 100 km/h:

DIP 1 (switch 8) is OFF (speed is in [km/h] unit)

DIP 2 (switch 8) is ON (+70)

DIP 2 (switch 4) is ON (+30)

Problem diagnostics

Symptom	LED	Description
Sensor repeatedly shows detections even without vehicle over the loop, or detection LED blinks erratically	Status LED: Always ON or Blinking Detection LED: No	Potential problems: damaged loop wiring, bad loop contact, loop moving in ground, cross-talk with adjacent devices or bad device installation. Possible solution: try changing loop oscillator frequency, filtering level or sensitivity level, try placing device in hermetically sealed plastic box to avoid air flowing over the device components.
Sensor does not detect	Status LED: Always ON Detection LED: Yes or No	Device is re-calibrating on start up or because of loop oscillator error. Please connect with PC Configurator Software to read what kind of error is present.